

Modular Cooking Range Line thermaline 90 - 23 lt Well Freestanding Gas Deep Fat Fryer, 1 Side H=700

ITEM # _____

MODEL # _____

NAME # _____

SIS # _____

AIA # _____



589302 (MCFDEADPO) 23lt gas Deep Fat Fryer,
 one-side operated

Short Form Specification

Item No. _____

Unit constructed according to DIN 18860_2 with 20 mm drop nose top and 70 mm recessed plinth. Internal frame for heavy duty sturdiness in stainless steel. 2 mm top in 1.4301 (AISI 304). Flat surface construction, easily cleanable. THERMODUL connection system enables seamless worktop when units are connected and avoids soil penetrating. Appliance designed to deep fry meat, fish and vegetables (french fries). Deep drawn V-shaped well with thermostatic regulation of oil temperature up to a maximum of 185 °C. Electrical ignition powered by battery with thermocouple for added safety. Flame failure device on each burner, with safety thermostat and thermostatic control. Reduced power setting to melt solid fat. Oil can be easily drained via a ball-valve. All-round basin raised edges to protect against soil infiltration. Large overflow stamped area around the well. Overheat protection switches off the supply in case of overheating. Metal knobs with embedded hygienic silicon "soft" grip enable easier handling and cleaning. IPX4 water resistant certification. Configuration: Freestanding, One-side operated.

Main Features

- All major components may be easily accessed from the front.
- THERMODUL connection system creates a seamless work top when units are connected to each other thus avoiding soil penetrating vital components and facilitating the removal of units in case of replacement or service.
- Metal knobs with embedded hygienic "soft-touch" grip for easier handling and cleaning. The special design of the controls prevents infiltration of liquids or soil into vital components.
- Overheat protection: the temperature sensor switches off the supply in case of overheating.
- Raised edge all around the well to protect from infiltration of dirt from worktop.
- Deep drawn V-Shaped well.
- Large overflow stamped area, located around the well.
- External heating elements allow to easily clean the well.
- Indirect oil heating system and uniform heat distribution to guarantee extended oil life.
- Reduced power setting to melt solid fat.
- Oil level mark for MAX/MIN filling.
- Designed for deep fat frying of meat, fish, specialities and vegetable (french fries, chips).
- Oil can be drained off via a ball-valve with a lock to prevent unintentional opening. When opened, the ball valve provides a full cross-section opening to easily clean the drainage system.
- Flame failure device on each burner.
- Safety thermostat and thermostatic control.
- Thermostatic regulation of oil temperature up to a maximum of 185 °C.
- Electrical ignition powered by battery with thermocouple for added safety.

Construction

- 2 mm top in 1.4301 (AISI 304).
- Unit constructed according to DIN 18860_2 with 20 mm drop nose top and 70 mm recessed plinth.
- Flat surface construction with minimal hidden areas to easily clean all surfaces
- IPx4 water protection.
- Internal frame for heavy duty sturdiness in stainless steel.

APPROVAL: _____

Front

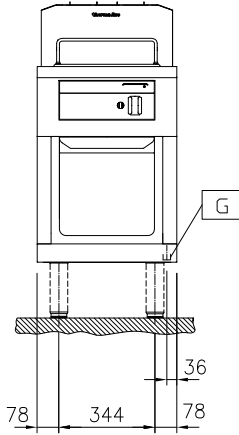

Side

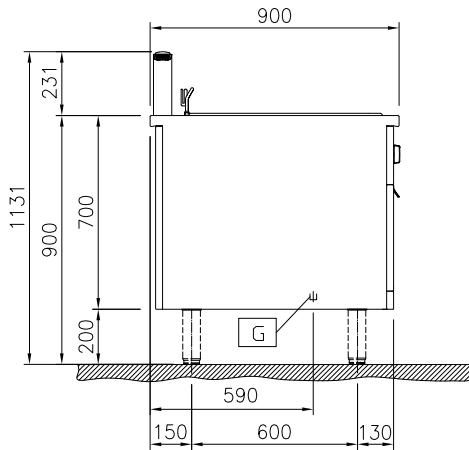

EQ = Equipotential screw
 G = Gas connection

Top

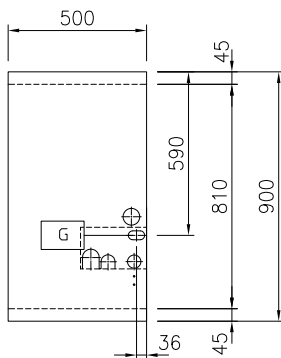

Gas

| | |
|------------------|-------|
| Gas Power: | 21 kW |
| Gas Type Option: | |
| Gas Inlet: | 1/2" |

Key Information:

| | |
|----------------------------------|----------------------------|
| Number of wells: | 1 |
| Usable well dimensions (width): | 340 mm |
| Usable well dimensions (height): | 250 mm |
| Usable well dimensions (depth): | 400 mm |
| Well capacity: | 20 lt MIN; 23 lt MAX |
| Thermostat Range: | 120 °C MIN; 190 °C MAX |
| External dimensions, Width: | 500 mm |
| External dimensions, Depth: | 900 mm |
| External dimensions, Height: | 700 mm |
| Net weight: | 85 kg |
| Configuration: | On Base; One-Side Operated |

Included Accessories
Optional Accessories

| | | | | | |
|--|------------|--------------------------|---|------------|--------------------------|
| • Discharge vessel for 14 & 23lt fryers | PNC 911570 | <input type="checkbox"/> | • Endrail kit, (12.5mm), for back-to-back installation, right | PNC 913252 | <input type="checkbox"/> |
| • Lid for discharge vessel 14 & 23lt fryers | PNC 911585 | <input type="checkbox"/> | • Endrail kit, flush-fitting, for back-to-back installation, left | PNC 913255 | <input type="checkbox"/> |
| • Connecting rail kit, 900mm | PNC 912502 | <input type="checkbox"/> | • Endrail kit, flush-fitting, for back-to-back installation, right | PNC 913256 | <input type="checkbox"/> |
| • Stainless steel side panel, 900x700mm, freestanding | PNC 912512 | <input type="checkbox"/> | • Side reinforced panel only in combination with side shelf, for freestanding units | PNC 913260 | <input type="checkbox"/> |
| • Portioning shelf, 500mm width | PNC 912523 | <input type="checkbox"/> | • Side reinforced panel only in combination with side shelf, for back-to-back installations, left | PNC 913275 | <input type="checkbox"/> |
| • Portioning shelf, 500mm width | PNC 912553 | <input type="checkbox"/> | • Side reinforced panel only in combination with side shelf, for back-to-back installation, right | PNC 913276 | <input type="checkbox"/> |
| • Folding shelf, 300x900mm | PNC 912581 | <input type="checkbox"/> | • Stainless steel dividing panel, 900x700mm, (it should only be used between Electrolux Professional thermaline Modular 90 and thermaline C90) | PNC 913672 | <input type="checkbox"/> |
| • Folding shelf, 400x900mm | PNC 912582 | <input type="checkbox"/> | • Stainless steel side panel, 900x700mm, flush-fitting (it should only be used against the wall, against a niche and in between Electrolux Professional thermaline and ProThermetic appliances and external appliances - provided that these have at least the same dimensions) | PNC 913688 | <input type="checkbox"/> |
| • Fixed side shelf, 200x900mm | PNC 912589 | <input type="checkbox"/> | | | |
| • Fixed side shelf, 300x900mm | PNC 912590 | <input type="checkbox"/> | | | |
| • Fixed side shelf, 400x900mm | PNC 912591 | <input type="checkbox"/> | | | |
| • Stainless steel front kicking strip, 500mm width | PNC 912631 | <input type="checkbox"/> | | | |
| • Stainless steel side kicking strip left and right, freestanding, 900mm width | PNC 912657 | <input type="checkbox"/> | | | |
| • Stainless steel side kicking strip left and right, back-to-back, 1810mm width | PNC 912663 | <input type="checkbox"/> | | | |
| • Stainless steel plinth, freestanding, 500mm width | PNC 912955 | <input type="checkbox"/> | | | |
| • Connecting rail kit: modular 90 (on the left) to ProThermetic tilting (on the right), ProThermetic stationary (on the left) to ProThermetic tilting (on the right) | PNC 912975 | <input type="checkbox"/> | | | |
| • Connecting rail kit: modular 80 (on the right) to ProThermetic tilting (on the left), ProThermetic stationary (on the right) to ProThermetic tilting (on the left) | PNC 912976 | <input type="checkbox"/> | | | |
| • Endrail kit, flush-fitting, left | PNC 913111 | <input type="checkbox"/> | | | |
| • Endrail kit, flush-fitting, right | PNC 913112 | <input type="checkbox"/> | | | |
| • Sediment tray for 23lt deep fat fryer | PNC 913144 | <input type="checkbox"/> | | | |
| • Filter for deep fat fryer oil collection basin | PNC 913146 | <input type="checkbox"/> | | | |
| • Endrail kit (12.5mm) for thermaline 90 units, left | PNC 913202 | <input type="checkbox"/> | | | |
| • Endrail kit (12.5mm) for thermaline 90 units, right | PNC 913203 | <input type="checkbox"/> | | | |
| • Stainless steel side panel, left, H=700 | PNC 913222 | <input type="checkbox"/> | | | |
| • Stainless steel side panel, right, H=700 | PNC 913223 | <input type="checkbox"/> | | | |
| • T-connection rail for back-to-back installations without backsplash (to be ordered as S-code) | PNC 913227 | <input type="checkbox"/> | | | |
| • Insert profile d=900 | PNC 913232 | <input type="checkbox"/> | | | |
| • Endrail kit, (12.5mm), for back-to-back installation, left | PNC 913251 | <input type="checkbox"/> | | | |